

# PM-238T-48

---

Adjustable Tapered Pipe Mount, 2-3/8 in OD x 48 in

## Product Classification

**Product Type** Pipe mount

## General Specifications

**Mounting** Saddle mounts

**Note** One 96 in x 8 in panel antenna per pipe mount

**Pipe, quantity** 1

**Tower Taper** Tapered

## Dimensions

**Height** 1,219.2 mm | 48 in

**Width** 152.4 mm | 6 in

**Length** 152.4 mm | 6 in

**Pipe Length** 1,219.2 mm | 48 in

**Pipe Outer Diameter** 60.96 mm | 2.4 in

# PM-238T-48

---

## Outline Drawing

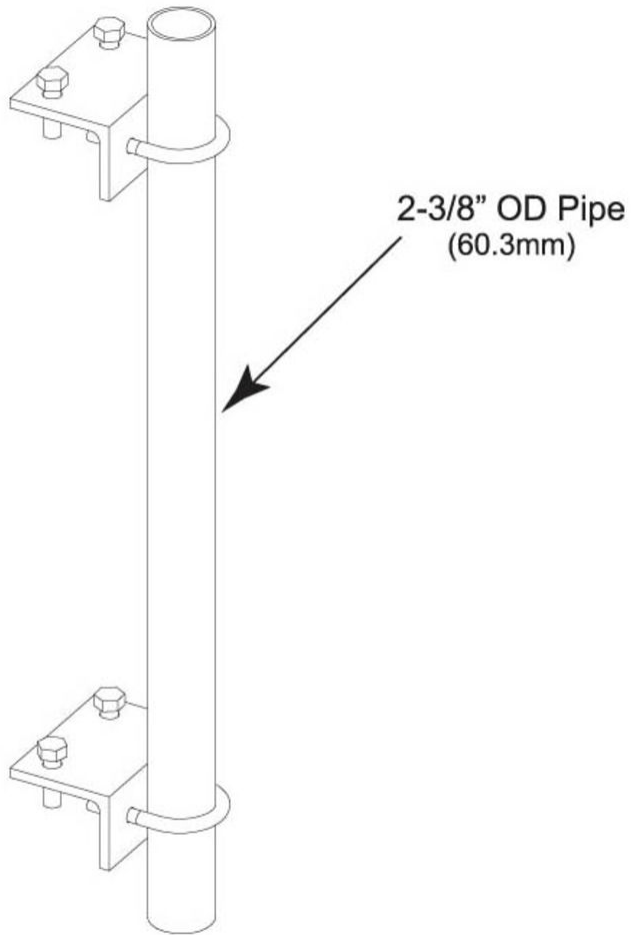

## Material Specifications

**Material Type** Hot dip galvanized steel

## Mechanical Specifications

**Wind Rating** 120 mph (BWS) at 150 ft AGL

**Wind Rating Test Method** TIA/EIA-222

## Packaging and Weights

**Included** Brackets | Hardware | Pipe

**Packaging quantity** 1

# PM-238T-48

---

**Weight, net** 6.4 kg | 14.11 lb

## Regulatory Compliance/Certifications

**Agency**

ISO 9001:2015

**Classification**

Designed, manufactured and/or distributed under this quality management system



## Included Products

MT-650 — Plain End Pipe, 2-3/8 in OD x 48 in

PM-TK — Pipe Mount Taper Kit

## \* Footnotes

**Wind Rating**

BWS—w Base Wind Speed; FBC—Florida Building Code