



Universal Tripod Mount, base only, pipe not included

## Product Classification

**Product Type** Tripod mount

## Dimensions

**Height** 838.2 mm | 33.0 in  
**Length** 1.5 m | 5.0 ft  
**Pipe Outer Diameter** 114.3 mm | 4.5 in  
**Weight** 78.7 kg | 173.4 lb  
**Width** 1524.0 mm | 60.0 in

## Environmental Specifications

**Wind Rating** 85 mph (BWS) at 100 ft AGL using Exposure C per UBC  
**Wind Rating Test Method** TIA/EIA-222

## General Specifications

**Mounting** Surfaces  
**Includes** Mount, with or without pipe  
**Material Type** Hot dip galvanized steel  
**Note** One 6 ft microwave antenna using 4-1/2 in pipe mast  
**Package Quantity** 1  
**Pipe, quantity** 0

## Outline Drawing

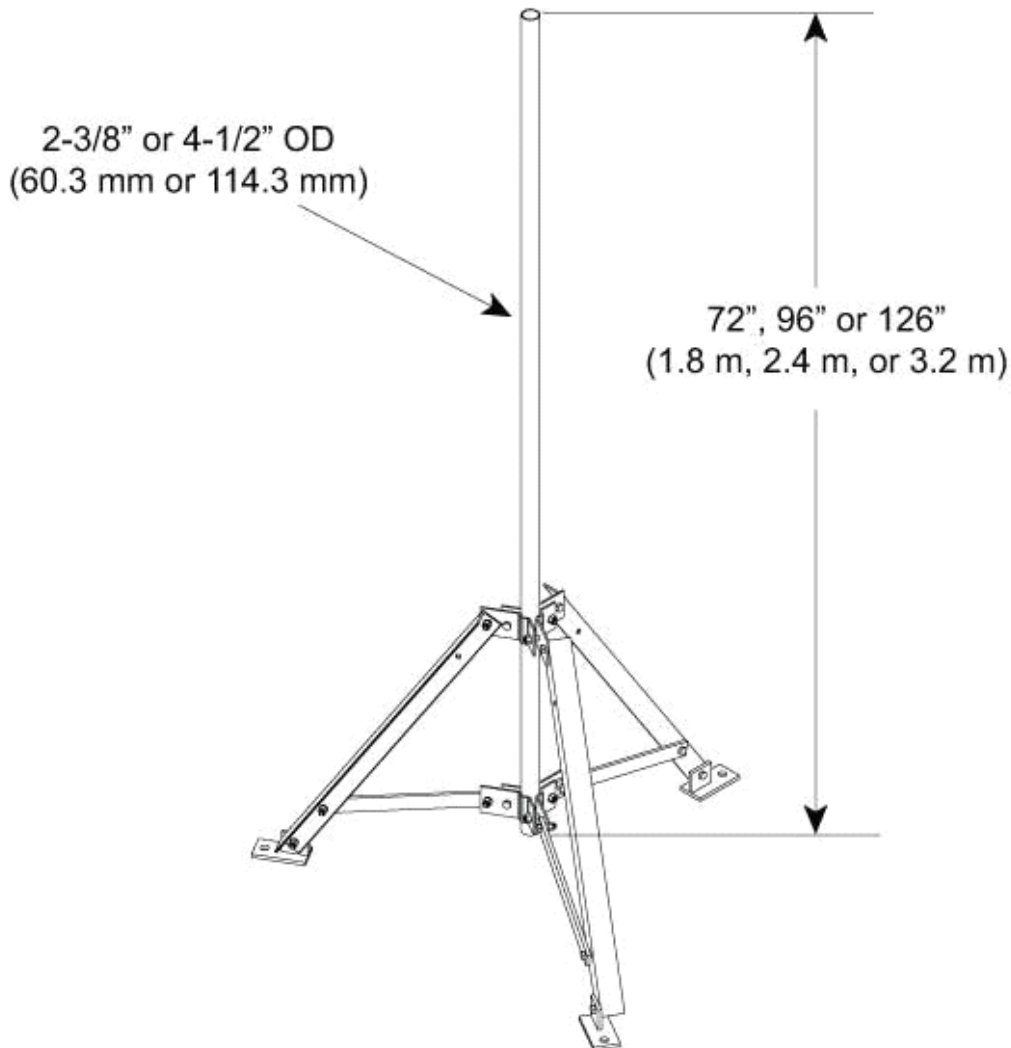

## Regulatory Compliance/Certifications

Agency	Classification
ISO 9001:2015	Designed, manufactured and/or distributed under this quality management system



## \* Footnotes

### **Wind Rating**

BWS—Base Wind Speed; FBC—Florida Building Code